

# Diesel Generator set QSX15 series engine

500kVA - 550kVA 50Hz  
450kW - 500kW 60Hz



> Specification sheet

Our energy working for you.™



## Description



This generator set is designed in facilities certified to ISO9001 and manufactured in facilities certified to ISO9001 or ISO9002.

This Cummins® Power Generation commercial generator set is a fully integrated power generation system, providing optimum performance, reliability, and versatility for stationary standby, prime power, and continuous duty applications.

### Generator Set Performance

#### Voltage Regulation

Maintains voltage output to within  $\pm 1.0\%$ .  
At any power factor between 0.8 and 1.0  
At any variations from No load to Full load.  
At any variations from Cold to Hot.

At speed droop variations up to 4.5%.

#### Frequency Regulation

Isochronous under varying loads from no load to 100% full load when electronic governor is fitted.

#### Random Frequency Variation

Will not exceed  $\pm 0.25\%$  of its mean value for constant loads – no load to full load.

#### Waveform

Total harmonic distortion open circuit voltage waveform in the order of 1.8%. Three-phase balanced load in the order of 5.0%.

#### Telephone Influence Factor (TIF)

TIF better than 50.

THF to BS 4999 Part 40 better than 2%.

#### Alternator Temperature Rise

Class H insulation.

#### Radio Interference

In compliance with BS 800 and VDE levels G and N.

## Features

Cummins® Heavy-Duty Engine - Rugged 4-cycle industrial diesel delivers reliable power, low emissions and fast response to load changes.

Permanent Magnet Generator (PMG) - Offers enhanced motor starting and fault clearing short circuit capability.

Alternator - Several alternator sizes offer selectable motor starting capability with low reactance 2/3 pitch windings; low waveform distortion with non-linear loads, fault clearing short-circuits capability, and class H insulation.

Control System - Standard PowerCommand® electronic control provides total system integration including remote start/stop, precise frequency and voltage regulation, alarm and status message display, AmpSentry protection, output metering, auto-shutdown.

Cooling System - Standard integral set-mounted radiator system, designed and tested for rated ambient temperatures, simplifies facility design requirements for rejected heat.

Enclosures - Optional weather-protective and sound-attenuated enclosures are available.

Warranty and Service - Backed by a comprehensive warranty and worldwide distributor network.

Model	Standby Rating		Prime Rating	
	50Hz kVA (kW)	60Hz kW (kVA)	50Hz kVA (kW)	60Hz kW (kVA)
C500 D5	500 (400)	N/A	450 (360)	N/A
C550 D5	550 (440)	N/A	500 (400)	N/A
C450 D6	N/A	450 (562.5)	N/A	410 (512.5)
C500 D6	N/A	500 (625)	N/A	455 (568.75)

## Generator Set Specifications

Governor Regulation Class	ISO8528
Voltage Regulation, No Load to Full Load	± 1%
Random Voltage Variation	± 1%
Frequency Regulation	Isochronous
Random Frequency Variation	± 0.25%
Radio Frequency Emissions Compliance	In compliance with BS 800 and VDE levels G and N.

## Engine Specifications

Design	4 cycle, in-line, Turbo Charged, Air-cooled
Bore	137 mm (5.39 in.)
Stroke	169 mm (6.65 in.)
Displacement	15 liter (912 in. <sup>3</sup> )
Cylinder Block	Cast iron, 6 cylinder
Battery Capacity	100 A/hr
Battery Charging Alternator	35 amps
Starting Voltage	24 volt, negative ground
Fuel System	Direct injection
Fuel Filter	Spin on fuel filters with water separator
Air Cleaner Type	Dry replaceable element with restriction indicator
Lube Oil Filter Type(s)	Spin on full flow filter
Standard Cooling System	122°F (50°C) ambient radiator

## Alternator Specifications

Design	Brushless single bearing, revolving field
Stator	2/3 pitch
Rotor	Single bearing, flexible disc
Insulation System	Class H
Standard Temperature Rise	163°C - 125°C Standby/Prime
Exciter Type	Self Excited
Phase Rotation	A (U), B (V), C (W)
Alternator Cooling	Direct drive centrifugal blower fan
AC Waveform Total Harmonic Distortion	No load < 1.5%. Non distorting balanced linear load < 5%
Telephone Influence Factor (TIF)	<50 per NEMA MG1-22.43
Telephone Harmonic Factor (THF)	<2%

## Available Voltages

50Hz Line – Neutral / Line - Line	60Hz Line – Neutral / Line - Line
<ul style="list-style-type: none"> <li>• 240/416</li> <li>• 230/400</li> <li>• 220/380</li> </ul>	<ul style="list-style-type: none"> <li>• 277/480</li> <li>• 220/380</li> <li>• 139/240</li> </ul>

## Generator Set Options

### Engine

- Heavy Duty air filter
- Water jacket heater 220/240 v

### Cooling

- Antifreeze 50/50 (Ethylene glycol)

### Enclosure

- Sound attenuated enclosure

### Alternator

- Alternator heater
- Exciter voltage regulator (PMG)

### Control Panel

- 4 pole Main Circuit Breaker
- PCC3201

### Silencer

- Critical silencer
- Residential silencer

Our energy working for you.™

[www.cumminspower.com](http://www.cumminspower.com)

© 2007 Cummins Power Generation Inc. All rights reserved. Cummins Power Generation and Cummins are registered trademarks of Cummins Inc. PowerCommand is a registered trademark of Cummins Power Generation Inc. "Our energy working for you." is a trademark of Cummins Power Generation.  
APSB-1153-07 (9/07)



## Control System - PCC2100



The PowerCommand™ 2100 Control is a microprocessor-based generator set monitoring, and control system. The control provides an operator interface to the genset, digital voltage regulation, digital governing and generator set protective functions.

The PowerCommand™ 2100 generator set control is suitable for use on a wide range of generator sets in non-paralleling applications.

The PowerCommand™ Control can be configured for any frequency, voltage and power connection configuration from 120 to 600VAC for 50Hz or 60Hz operation.

Power for the control is derived from the generator set starting batteries. The control functions over a voltage range from 8VDC to 35VDC.

### Major Features

- 12 or 24 VDC Battery Operation.
- Digital Engine Speed Governing (optional) to provide isochronous frequency regulation.
- Digital Voltage Regulation with 3-phase sensing
- AmpSentry™ Protection for true alternator overcurrent protection.
- Digital AC Output Metering with Optional Analog Metering.
- Battery Monitoring System to sense and warn against a weak battery condition.
- Digital Alarm and Status Message Display
- Generator set Monitoring: Displays status of all critical engine and alternator generator set functions.
- Smart Starting Control System: Integrated fuel ramping to limit black smoke and frequency overshoot.
- Advanced Serviceability using InPower™, a PC-based software service tool.

### Control System

Includes all functions to locally or remotely start and stop, and protect the generator set.

Control Switch - RUN/OFF/AUTO

OFF Mode - the generator set is shut down and cannot be started

RUN mode the generator set will execute its start sequence

AUTO mode, the generator set can be started with a start signal from a remote device

LED Indicating Lamps - includes LED indicating lamps for the following functions:

Generator set running

Not-in-auto mode

Common warning

Five LED indicating lamps that are configurable for colour and function

Low oil pressure warning

High engine temperature warning

Low oil pressure shutdown

Overspeed shutdown

Fail to start

Emergency Stop Switch. Immediate shut down of the generator set on operation.

Base Engine Protection:

Overspeed shutdown

Low Oil Pressure Warning / Shutdown

High Engine Temperature Warning / Shutdown

Underspeed / Sensor Fail Shutdown

Fail to Start / Fail to Crank

Low / high battery voltage

### Options

Analog AC Metering Panel

Key Type Mode Selector Switch

Exhaust Temperature Monitoring

PowerCommand Network

CAN Engine Interface (Optional on Some Models)

Refer to the PowerCommand Controls Technical Bulletin for detailed information (S1409d)

Our energy working for you.™

[www.cumminspower.com](http://www.cumminspower.com)

## Ratings Definitions

Standby:	Limited Time Running:	Prime (Unlimited Running Time):	Base Load (Continuous):
Applicable for supplying power to varying electrical load for the duration of power interruption of a reliable utility source. Emergency Standby Power (ESP) is in accordance with ISO 8528. Fuel Stop power in accordance with ISO 3046, AS 2789, DIN 6271 and BS 5514.	Applicable for supplying power to a constant electrical load for limited hours. Limited Time Running Power is in accordance with ISO 8528.	Applicable for supplying power to varying electrical load for unlimited hours. Prime Power is in accordance with ISO 8528. Ten percent overload capability is available in accordance with ISO 3046, AS 2789, DIN 6271 and BS 5514.	Applicable for supplying power continuously to a constant electrical load for unlimited hours. Continuous power in accordance with ISO 8528, ISO 3046, AS 2789, DIN 6271 and BS 5514.

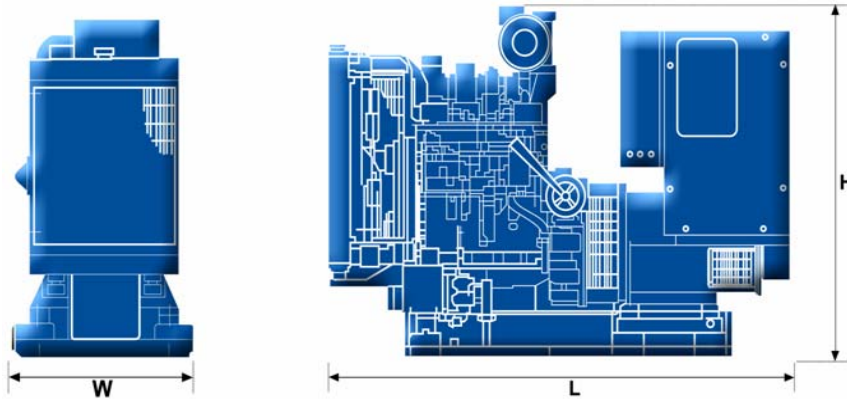

This outline drawing is to provide representative configuration details for Model series only.  
See respective model data sheet for specific model outline drawing number.

**Do not use for installation design.**

Model	Length (mm)	Width (mm)	Height (mm)	Set weight dry kg	Set weight wet kg
C500 D5	3494	1500	1807	3700	3860
C550 D5	3494	1500	1807	3850	4010
C450 D6	3494	1500	1807	3700	3860
C500 D6	3494	1500	1807	3700	3860

### Cummins Power Generation

#### Asia Pacific

10 Toh Guan Road #07-01  
TT International Tradepark  
Tel: (65) 6417 2388  
Fax: (65) 6417 2399  
E-Mail: [cpg.apmktg@cummins.com](mailto:cpg.apmktg@cummins.com)

Our energy working for you.™

[www.cumminspower.com](http://www.cumminspower.com)

© 2007 Cummins Power Generation Inc. All rights reserved. Cummins Power Generation and Cummins are registered trademarks of Cummins Inc. PowerCommand is a registered trademark of Cummins Power Generation Inc. "Our energy working for you." is a trademark of Cummins Power Generation.  
APSB-1153-07 (9/07)

